

BATTERY  
**CSB**



CSB Powers Your Business

Confidence & Creativity  
 Service & Sincerity  
 Belief & Bravery



Superior Cycle Life  
 Improved Performance  
 Dependable

**EVX**

# EVX series

EVX -series batteries are specially designed for equipment such as electric cars, bicycles, wheelchairs, golf and shopping carts, etc. With VRLA technology, A product of intensive R&D, the EVX series is small, lightweight, and suitable for numerous charges. It can be used for more than 400 cycles at 100% discharge, or up to 8 years in standby service. As with all CSB batteries, they are rechargeable, efficient, maintenance-free, leakproof, suitable in any orientation and ISO/UL certified.



## Performance

- 100% capacity on first discharge.
- Innovative PAM manufacturing technique increases cycle by 150% over standard sealed Pb-acid..
- Uniformed plate formation for consistent capacity.
- Hundreds to thousands of recharge cycles (cycle life is based on temperature and depth of discharge).
- No-spill design.
- Maintenance-free.
- Reduced internal resistance for superior performance.

## Long service life

- More than 400 cycles at 100% discharge cycle use.
- Up to 8 years expected life under normal float charge conditions at 25 °C (77 °F).
- Extended shelf life (up to 14 months at 20 °C).

## Reliability

- CSB-manufactured batteries are 100% 2-cycle tested by CCDS.
- CSB-manufactured batteries are UL-recognized components under UL 1989. CSB file number MH 14533.
- ISO 9001 and 14001 certified.

## Applications

### Cycle use

- Electric vehicles.
- Golf carts.
- Portable telephone sets.
- Portable lighting equipment.
- Power tools, lawn mowers, vacuum cleaners.
- Portable measuring equipment.
- Cameras and photographic equipment.
- Portable VTR/TV, tape recorders and radios.
- Portable personal computers and processors.

### Standby use

- UPS.
- Communications and electrical equipment.
- Office computers, microcomputers and other OA Equipment.
- Robots, control equipment and other FA equipment.
- Emergency power supply in power generation plants and substations.

### Solar Cell Power Generation

- Street lighting.
- Portable power supply.
- Water pumping.
- Rural power systems.

## Trickle (or Float) Service Life

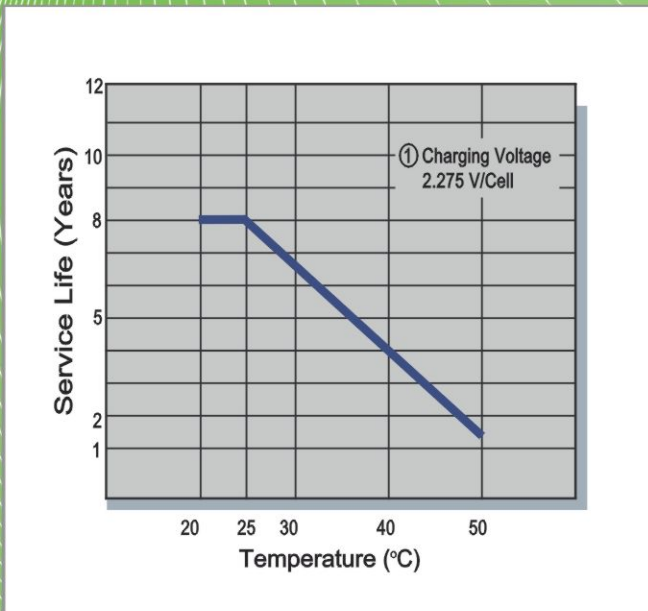

## Capacity Retention Characteristic

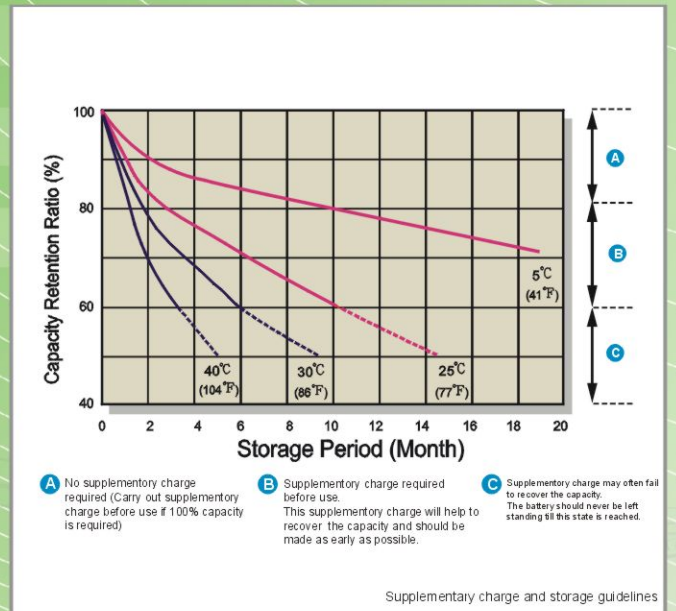

## Battery Voltage and Charge Time for Standby Use

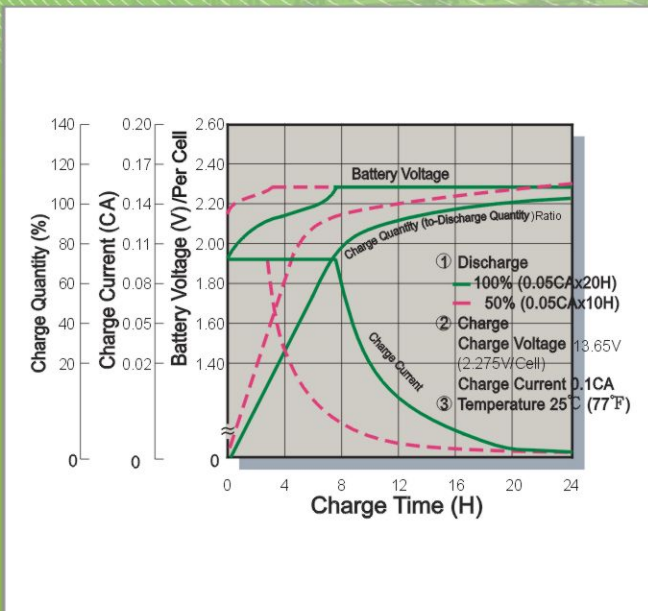

## Cycle Service Life

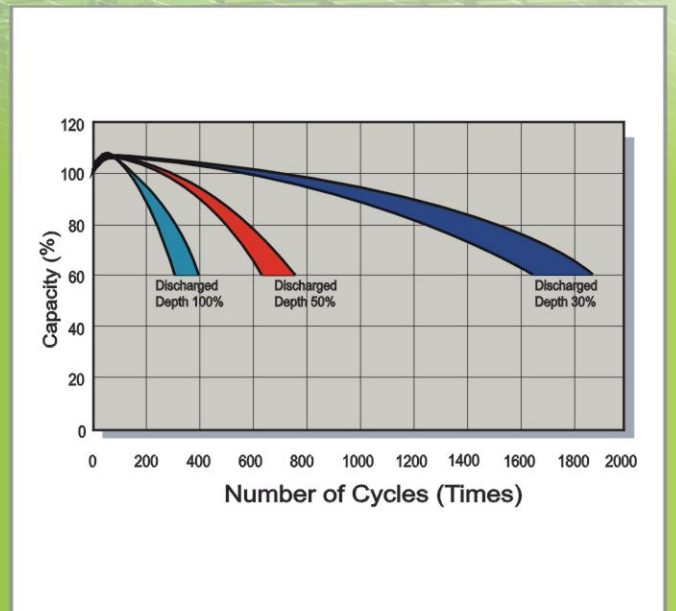

## Battery Voltage and Charge Time for Cycle Use

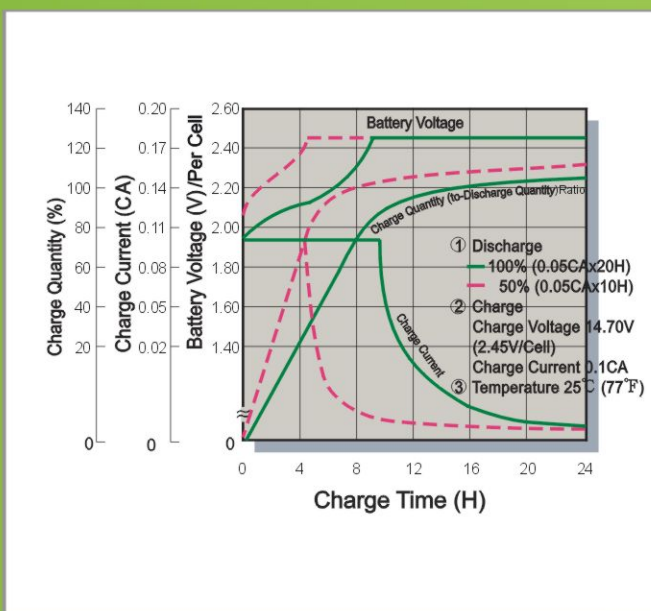

## Terminal Voltage (V) and Discharge Time

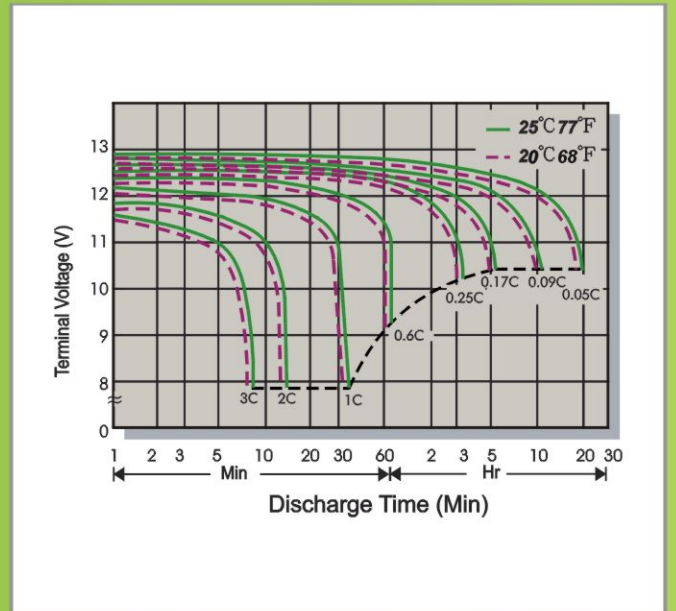

## Specifications

Battery Type	Nominal Voltage(V)	Nominal Capacity (20Hr)(Ah)	Weight (Approx. Kg)	Energy Density (Wh/l)	Specific Energy (Wh/kg)	Internal Resistance Approx. (mΩ)	Max. Discharge Current 5 sec (A)	Dimensions (mm)				Terminal Position	Terminal Type	Max. Charging Current (A)	Max. Screw Torque value	
								Overall Height (H)	Container Height (h)	Length (L)	Width (W)				kgf-cm/lbf-in	N-m
EVX1272	12	7.2	2.55	93.6	33.88	26.00	100/130	100±1.0	94±1.0	151±2.0	65±1.0	e	F1/F2	2.16	--	--
EVX12120	12	12.0	3.83	103.5	37.60	18.50	150/180	100±1.0	94±1.0	151±2.0	98±1.0	e	F1/F2	3.60	--	--
EVX12170	12	17.0	5.67	89.4	35.98	16.50	230	167±2.0	165.5±2.0	181±2.0	76.2±1.0	d	B1/B3	5.10	65/56	6.37
EVX12200	12	20.0	6.70	108.8	35.82	14.00	230	167±2.0	160±2.0	181±2.0	76.2±1.0	d	I1	6.00	65/56	6.37
EVX12260	12	26.0	8.65	88.0	36.07	11.50	350	125±1.5	122±1.5	175±2.0	166±2.0	d	B1/B3/B3B	7.80	65/56	6.37
EVX12300	12	30.0	10.40	99.1	34.62	9.00	400	175±2.0	175±2.0	166±2.0	125±1.5	c	I1	9.00	65/56	6.37
EVX12340	12	34.0	10.77	103.7	37.88	8.50	400	178.3±2.0	154.8±2.0	195.6±2.0	130±1.5	c	B5	10.20	127/110	12.45
EVX12400	12	40.0	12.73	87.6	37.71	10.00	400	170±2.0	168.5±2.0	197±2.0	165±2.0	d	B2	12.00	65/56	6.37
EVX12520	12	52.0	18.30	90.3	34.10	5.50	500	219.3±2.0	201.3±2.0	248±2.0	138.4±1.5	c	B4	15.60	127/110	12.45
EVX12650	12	65.0	22.20	78.0	35.14	8.00	500	174±2.0	172.5±2.0	349.4±2.5	166±2.0	d	B4	19.50	127/110	12.45
EVX12750	12	75.0	27.00	92.0	33.33	4.50	500	233.2±2.5	211.2±2.5	275±2.5	168.5±2.0	c	B6	22.50	286/248	28.05

**Charging(V) :** • Standby Use : 2.275V±0.025V/CELL AT 25°C (77°F) Temp Coefficient -3.3mV/CELL°C

• Cycle Use : 2.45V±0.05V/CELL AT 25°C (77°F) Temp Coefficient -5mV/CELL°C

## Terminal Position

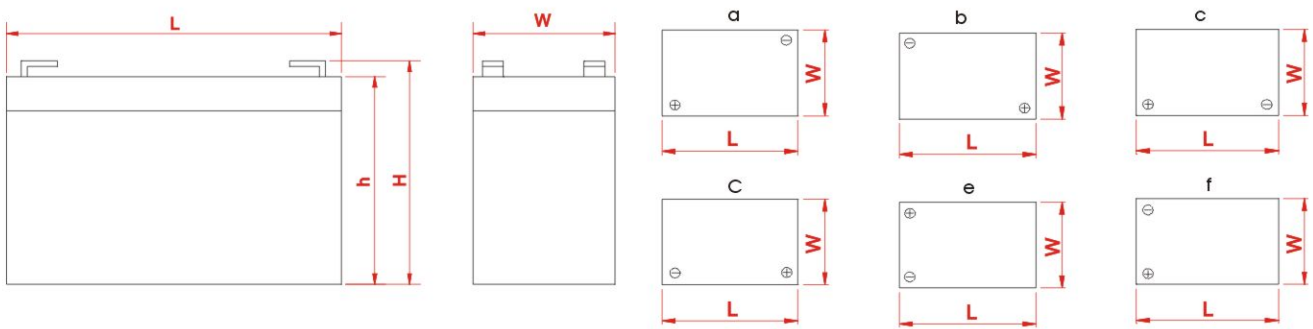

## Terminal Type

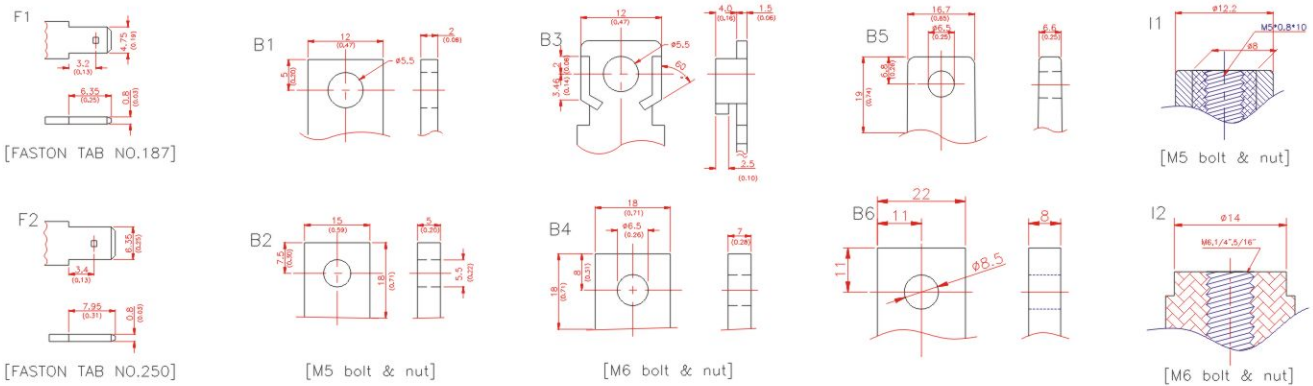

## EVX1272

### Constant Current Discharge Characteristics Unit:Amperes(25°C, 77°F)

F.V/Time	30MIN	60MIN	90MIN	2HR	3HR	4HR	5HR	8HR	10HR	20HR
1.60V	7.01	4.19	3.08	2.48	1.79	1.44	1.20	0.820	0.680	0.395
1.67V	6.79	4.04	2.98	2.40	1.72	1.39	1.16	0.785	0.652	0.381
1.70V	6.57	3.91	2.89	2.34	1.68	1.36	1.13	0.770	0.640	0.375
1.75V	6.38	3.80	2.81	2.27	1.63	1.32	1.10	0.745	0.620	0.360
1.80V	6.20	3.70	2.73	2.19	1.58	1.28	1.07	0.720	0.600	0.345
1.85V	6.00	3.58	2.65	2.13	1.53	1.24	1.04	0.695	0.580	0.330

### Constant Power Discharge Characteristics Unit:Watts(25°C, 77°F)

F.V/Time	30MIN	60MIN	90MIN	2HR	3HR	4HR	5HR	8HR	10HR	20HR
1.60V	84.1	50.3	37.0	29.6	21.5	17.3	14.4	9.81	8.20	4.53
1.67V	81.4	48.8	35.8	28.8	20.9	16.8	14.0	9.50	7.86	4.34
1.70V	79.2	47.3	34.8	27.9	20.2	16.3	13.6	9.24	7.72	4.27
1.75V	76.8	45.9	33.8	27.1	19.6	15.8	13.2	8.96	7.49	4.13
1.80V	74.4	44.4	32.7	26.2	19.0	15.3	12.8	8.67	7.25	4.00
1.85V	72.0	43.0	31.7	25.4	18.4	14.8	12.4	8.39	7.02	3.86

## EVX12120

Constant Current Discharge Characteristics Unit:Amperes(25°C, 77°F)										
F.V/Time	30MIN	60MIN	90MIN	2HR	3HR	4HR	5HR	8HR	10HR	20HR
1.60V	12.8	7.52	5.46	4.32	3.14	2.45	2.06	1.36	1.13	0.655
1.67V	12.7	7.45	5.45	4.29	3.10	2.44	2.05	1.35	1.12	0.633
1.70V	12.6	7.40	5.41	4.28	3.09	2.43	2.04	1.34	1.11	0.615
1.75V	12.4	7.37	5.36	4.25	3.07	2.41	2.01	1.33	1.09	0.600
1.80V	12.0	7.18	5.28	4.17	3.00	2.38	1.99	1.32	1.07	0.585
1.85V	11.3	6.89	5.08	3.99	2.90	2.30	1.92	1.27	1.04	0.570

Constant Power Discharge Characteristics Unit:Watts(25°C, 77°F)										
F.V/Time	30MIN	60MIN	90MIN	2HR	3HR	4HR	5HR	8HR	10HR	20HR
1.60V	146	86.1	63.4	50.5	36.8	29.3	24.4	16.2	13.4	7.13
1.67V	146	85.7	62.9	50.1	36.6	29.1	24.3	16.1	13.3	7.09
1.70V	144	85.2	62.7	50.0	36.4	28.9	24.2	16.0	13.2	7.06
1.75V	143	84.9	62.3	49.5	36.2	28.8	23.9	15.9	13.1	7.01
1.80V	140	83.5	61.2	49.0	35.7	28.5	23.7	15.7	12.9	6.87
1.85V	132	80.0	59.4	47.4	34.5	27.7	23.0	15.2	12.5	6.66

## EVX12170

Constant Current Discharge Characteristics Unit:Amperes(25°C, 77°F)										
F.V/Time	30MIN	60MIN	90MIN	2HR	3HR	4HR	5HR	8HR	10HR	20HR
1.60V	17.0	10.3	7.34	5.94	4.43	3.55	2.92	1.98	1.63	0.925
1.67V	16.5	9.94	7.14	5.77	4.28	3.43	2.84	1.92	1.58	0.904
1.70V	16.0	9.67	6.91	5.62	4.16	3.34	2.76	1.87	1.54	0.875
1.75V	15.5	9.38	6.69	5.43	4.03	3.24	2.68	1.81	1.49	0.850
1.80V	15.0	9.08	6.48	5.25	3.91	3.14	2.59	1.75	1.44	0.825
1.85V	14.5	8.79	6.27	5.09	3.79	3.04	2.51	1.69	1.39	0.800

Constant Power Discharge Characteristics Unit:Watts(25°C, 77°F)										
F.V/Time	30MIN	60MIN	90MIN	2HR	3HR	4HR	5HR	8HR	10HR	20HR
1.60V	204	123	88.1	71.6	53.1	42.6	35.0	23.8	19.6	10.8
1.67V	198	120	85.5	69.5	51.3	41.3	34.1	23.1	18.8	10.4
1.70V	192	116	82.9	67.9	49.9	40.1	33.1	22.4	18.5	10.2
1.75V	186	113	80.4	65.5	48.4	38.9	32.1	21.7	17.9	9.90
1.80V	180	109	77.8	63.3	46.9	37.7	31.1	21.0	17.3	9.59
1.85V	174	106	75.3	61.4	45.4	36.5	30.1	20.3	16.7	9.29

## EVX12200

Constant Current Discharge Characteristics Unit:Amperes(25°C, 77°F)										
F.V/Time	30MIN	60MIN	90MIN	2HR	3HR	4HR	5HR	8HR	10HR	20HR
1.60V	20.6	12.5	9.25	7.43	5.28	4.19	3.45	2.30	1.89	1.09
1.67V	20.0	12.3	8.99	7.25	5.15	4.10	3.35	2.23	1.84	1.05
1.70V	19.5	11.9	8.76	7.03	5.02	3.99	3.26	2.18	1.80	1.04
1.75V	18.9	11.6	8.50	6.79	4.85	3.85	3.16	2.12	1.75	1.00
1.80V	18.2	11.1	8.17	6.50	4.68	3.69	3.03	2.03	1.68	0.960
1.85V	17.4	10.6	7.84	6.22	4.49	3.52	2.89	1.95	1.62	0.920

Constant Power Discharge Characteristics Unit:Watts(25°C, 77°F)										
F.V/Time	30MIN	60MIN	90MIN	2HR	3HR	4HR	5HR	8HR	10HR	20HR
1.60V	247	150	111	88.7	63.4	50.3	41.4	27.6	22.7	12.3
1.67V	240	147	108	86.2	61.6	48.9	40.2	26.8	22.0	11.9
1.70V	233	143	105	83.7	60.0	47.5	39.1	26.0	21.5	11.7
1.75V	226	138	101	80.6	58.1	45.9	37.6	25.2	20.8	11.3
1.80V	218	133	98.0	77.4	56.1	44.3	36.3	24.3	20.1	10.8
1.85V	209	127	94.0	74.4	53.8	42.3	34.6	23.3	19.3	10.4

## EVX12260

Constant Current Discharge Characteristics Unit:Amperes(25°C, 77°F)										
F.V/Time	30MIN	60MIN	90MIN	2HR	3HR	4HR	5HR	8HR	10HR	20HR
1.60V	27.3	16.5	11.8	9.54	7.03	5.66	4.68	3.18	2.63	1.44
1.67V	26.5	16.0	11.4	9.22	6.82	5.49	4.56	3.09	2.56	1.41
1.70V	25.7	15.5	11.1	8.97	6.59	5.32	4.43	3.00	2.48	1.37
1.75V	24.9	15.0	10.8	8.68	6.39	5.16	4.30	2.91	2.40	1.33
1.80V	24.1	14.6	10.4	8.41	6.19	5.00	4.16	2.81	2.32	1.28
1.85V	23.3	14.1	10.1	8.13	5.99	4.84	4.03	2.72	2.24	1.24

Constant Power Discharge Characteristics Unit:Watts(25°C, 77°F)										
F.V/Time	30MIN	60MIN	90MIN	2HR	3HR	4HR	5HR	8HR	10HR	20HR
1.60V	328	198	141	114	84.3	67.9	56.2	38.2	31.5	17.3
1.67V	318	192	137	111	81.4	65.7	54.6	37.2	30.6	16.9
1.70V	308	186	133	107	79.1	63.8	53.2	36.0	29.7	16.4
1.75V	299	181	129	104	76.7	61.9	51.6	34.9	28.8	15.9
1.80V	289	175	125	101	74.3	60.0	49.9	33.7	27.8	15.4
1.85V	280	170	121	97.1	71.9	58.1	48.3	32.6	26.9	14.9

**EVX12300****Constant Current Discharge Characteristics Unit:Amperes(25°C, 77°F)**

F.V/Time	30MIN	60MIN	90MIN	2HR	3HR	4HR	5HR	8HR	10HR	20HR
1.60V	31.2	17.7	12.7	10.3	7.48	6.05	5.03	3.39	2.82	1.61
1.67V	30.6	17.3	12.3	9.94	7.25	5.87	4.90	3.29	2.75	1.58
1.70V	30.0	16.8	11.9	9.66	7.04	5.70	4.76	3.21	2.68	1.54
1.75V	29.2	16.3	11.6	9.38	6.82	5.54	4.64	3.12	2.61	1.50
1.80V	28.4	15.8	11.3	9.07	6.61	5.37	4.51	3.04	2.53	1.45
1.85V	27.6	15.3	10.9	8.79	6.39	5.21	4.39	2.94	2.46	1.41

**Constant Power Discharge Characteristics Unit:Watts(25°C, 77°F)**

F.V/Time	30MIN	60MIN	90MIN	2HR	3HR	4HR	5HR	8HR	10HR	20HR
1.60V	374	212	152	123	89.8	72.6	60.4	40.1	33.1	17.3
1.67V	367	207	147	120	87.1	70.4	58.6	39.1	32.2	16.8
1.70V	359	202	143	116	84.5	68.4	57.1	38.1	31.4	16.4
1.75V	351	196	139	112	81.9	66.4	55.6	37.0	30.5	15.9
1.80V	341	190	135	109	79.3	64.4	54.1	35.9	29.5	15.4
1.85V	332	184	131	105	76.7	62.4	52.6	34.7	28.4	14.9

**EVX12340****Constant Current Discharge Characteristics Unit:Amperes(25°C, 77°F)**

F.V/Time	30MIN	60MIN	90MIN	2HR	3HR	4HR	5HR	8HR	10HR	20HR
1.60V	34.5	20.2	14.6	11.6	8.25	6.53	5.39	3.63	3.06	1.85
1.67V	33.6	19.8	14.5	11.5	8.19	6.49	5.34	3.57	3.02	1.80
1.70V	32.8	19.5	14.3	11.3	8.12	6.42	5.28	3.51	2.95	1.76
1.75V	31.8	19.1	14.0	11.2	8.02	6.36	5.22	3.46	2.90	1.72
1.80V	30.8	18.7	13.8	11.0	7.86	6.27	5.14	3.41	2.86	1.69
1.85V	29.9	18.3	13.5	10.8	7.74	6.12	5.07	3.36	2.82	1.65

**Constant Power Discharge Characteristics Unit:Watts(25°C, 77°F)**

F.V/Time	30MIN	60MIN	90MIN	2HR	3HR	4HR	5HR	8HR	10HR	20HR
1.60V	414	242	175	141	99.0	78.4	64.7	43.6	36.0	19.5
1.67V	404	238	173	139	98.3	78.0	64.1	42.8	35.3	19.0
1.70V	393	234	171	137	97.4	77.4	63.4	42.2	34.6	18.5
1.75V	382	229	168	135	96.3	76.5	62.6	41.5	33.9	18.0
1.80V	370	224	165	132	95.1	75.5	61.8	40.9	33.4	17.6
1.85V	359	219	162	130	93.7	74.2	60.8	40.3	32.9	17.1

**EVX12400****Constant Current Discharge Characteristics Unit:Amperes(25°C, 77°F)**

F.V/Time	30MIN	60MIN	90MIN	2HR	3HR	4HR	5HR	8HR	10HR	20HR
1.60V	38.1	22.9	16.8	13.4	9.75	7.76	6.42	4.31	3.59	2.17
1.67V	37.0	22.3	16.3	13.0	9.47	7.52	6.23	4.18	3.49	2.12
1.70V	35.8	21.7	15.8	12.7	9.17	7.33	6.07	4.05	3.40	2.05
1.75V	34.8	21.0	15.3	12.3	8.88	7.09	5.91	3.94	3.30	2.00
1.80V	33.7	20.3	14.8	11.9	8.58	6.89	5.70	3.82	3.17	1.94
1.85V	32.6	19.5	14.4	11.4	8.29	6.62	5.48	3.68	3.09	1.89

**Constant Power Discharge Characteristics Unit:Watts(25°C, 77°F)**

F.V/Time	30MIN	60MIN	90MIN	2HR	3HR	4HR	5HR	8HR	10HR	20HR
1.60V	457	275	201	162	117	93.0	76.8	49.9	41.1	22.3
1.67V	444	268	196	157	113	90.1	74.6	48.4	40.0	21.6
1.70V	430	260	189	152	110	87.6	72.3	46.9	38.8	20.9
1.75V	417	252	184	147	107	84.5	69.9	45.5	37.6	20.3
1.80V	404	243	178	143	103	81.5	67.4	44.0	36.4	19.6
1.85V	391	235	173	138	99.5	78.9	64.9	42.6	35.2	19.0

**EVX12520****Constant Current Discharge Characteristics Unit:Amperes(25°C, 77°F)**

F.V/Time	30MIN	60MIN	90MIN	2HR	3HR	4HR	5HR	8HR	10HR	20HR
1.60V	64.9	36.8	27.0	21.0	14.8	11.7	9.60	6.60	5.42	2.84
1.67V	63.5	36.4	26.8	20.8	14.6	11.6	9.52	6.52	5.36	2.80
1.70V	62.1	35.8	26.5	20.6	14.5	11.5	9.45	6.45	5.29	2.76
1.75V	60.6	35.2	26.1	20.3	14.3	11.4	9.37	6.34	5.21	2.72
1.80V	59.2	34.7	25.6	20.1	14.2	11.3	9.26	6.22	5.12	2.67
1.85V	57.8	34.2	25.1	19.9	14.1	11.2	9.16	6.11	5.03	2.62

**Constant Power Discharge Characteristics Unit:Watts(25°C, 77°F)**

F.V/Time	30MIN	60MIN	90MIN	2HR	3HR	4HR	5HR	8HR	10HR	20HR
1.60V	668	386	284	221	154	124	102	70.9	58.7	33.6
1.67V	656	382	281	219	153	123	101	70.2	58.1	33.1
1.70V	645	378	277	217	152	122	100	69.4	57.4	32.5
1.75V	631	372	273	214	151	121	99.0	68.6	56.7	31.8
1.80V	615	368	269	212	150	120	98.1	67.6	55.8	31.1
1.85V	598	363	264	209	149	119	97.0	66.1	54.8	30.4

**EVX12650****Constant Current Discharge Characteristics Unit:Amperes(25°C, 77°F)**

F.V/Time	30MIN	60MIN	90MIN	2HR	3HR	4HR	5HR	8HR	10HR	20HR
1.60V	70.5	41.2	30.0	23.9	17.0	13.4	11.1	7.57	6.31	3.38
1.67V	69.9	41.1	29.8	23.7	16.9	13.3	11.0	7.54	6.28	3.35
1.70V	69.4	40.8	29.6	23.6	16.8	13.2	10.9	7.50	6.24	3.34
1.75V	68.3	40.4	29.4	23.4	16.7	13.1	10.8	7.42	6.16	3.31
1.80V	65.7	39.4	28.8	23.0	16.4	12.9	10.7	7.28	6.04	3.23
1.85V	61.3	37.4	27.5	22.0	15.7	12.4	10.2	6.99	5.78	3.11

**Constant Power Discharge Characteristics Unit:Watts(25°C, 77°F)**

F.V/Time	30MIN	60MIN	90MIN	2HR	3HR	4HR	5HR	8HR	10HR	20HR
1.60V	806	484	353	279	199	158	132	90.0	74.7	40.3
1.67V	804	481	351	277	198	157	130	89.6	74.3	40.2
1.70V	795	477	350	276	197	156	129	89.2	74.2	40.0
1.75V	784	475	347	275	196	155	128	88.2	73.2	39.7
1.80V	759	467	342	270	193	151	127	86.9	72.0	38.9
1.85V	714	446	329	259	186	147	122	83.2	68.9	37.8

**EVX12750****Constant Current Discharge Characteristics Unit:Amperes(25°C, 77°F)**

F.V/Time	30MIN	60MIN	90MIN	2HR	3HR	4HR	5HR	8HR	10HR	20HR
1.60V	83.2	49.3	35.7	28.1	19.9	15.6	12.8	8.35	6.82	3.84
1.67V	81.6	48.6	35.2	27.6	19.7	15.4	12.7	8.25	6.74	3.80
1.70V	80.1	47.8	34.6	27.2	19.4	15.2	12.5	8.15	6.67	3.77
1.75V	78.1	46.8	33.9	26.7	19.2	15.0	12.4	8.07	6.60	3.75
1.80V	75.8	45.7	33.2	26.2	18.9	14.8	12.2	7.98	6.54	3.72
1.85V	73.3	44.4	32.5	25.7	18.6	14.6	12.0	7.89	6.47	3.68

**Constant Power Discharge Characteristics Unit:Watts(25°C, 77°F)**

F.V/Time	30MIN	60MIN	90MIN	2HR	3HR	4HR	5HR	8HR	10HR	20HR
1.60V	924	538	392	313	226	177	146	95.2	77.5	41.4
1.67V	906	532	386	309	223	175	144	94.3	77.0	41.2
1.70V	887	524	380	304	219	172	142	93.4	76.4	41.0
1.75V	863	513	373	299	216	170	140	92.3	75.7	40.7
1.80V	839	500	367	293	213	168	139	91.3	75.0	40.6
1.85V	813	484	359	288	210	165	137	90.3	74.2	39.8

All information is subject to change without (prior) notification. Please consult CSB website ([www.csb-battery.com](http://www.csb-battery.com)) for latest information.

The image features a blue CSB EVX12650 battery with technical specifications: EVX 12650, 12V 40Ah, CSB BATTERY CO., LTD., MADE IN TAIWAN. The background is a green gradient with a large 'FUTURE' banner and the CSB logo. The slogan 'CSB Powers Your Business' is displayed at the bottom.

BATTERY



## SALES OFFICE

### GLOBAL HQ

CSB BATTERY CO., LTD.  
11F, No. 150, Sec. 4, Chengde Rd.,  
Shilin Dist., Taipei City 11167,  
Taiwan (R.O.C.)  
Tel : +886-2-2880-5600  
Fax : +886-2-2888-3300  
E-mail : [service@csb-battery.com.tw](mailto:service@csb-battery.com.tw)

### FRANCE OFFICE

CSB BATTERY FRANCE S.A.R.L  
10, rue Boris Vian  
95310 Saint Ouen l'Aumone  
France  
Tel : +33 (0) 134201746  
Fax : +33 (0) 134201748  
E-mail : [eurosales@csb-battery.eu](mailto:eurosales@csb-battery.eu)

### SPAIN OFFICE

CSB BATTERY IBERICA S.L.  
Calle Doctor Esquerdo, 167 1 A y B.  
28007 Madrid,  
Spain  
Tel : +34 - 686409770  
E-mail : [eurosales@csb-battery.eu](mailto:eurosales@csb-battery.eu)

### BEIJING OFFICE (CHINA)

CSB BATTERY TECHNOLOGIES (BEIJING) CO., LTD.  
Room 702, 12th Building, Wanda Plaza,  
Jianguo Rd., Chaoyang Dis.,  
Beijing, China  
PC : 100022  
Tel : +86-10-58205336 / +86-10-58205338  
Fax : +86-10-58203053  
E-mail : [chinasls@csb-battery.com](mailto:chinasls@csb-battery.com)

## MANUFACTURING SITE

### CHINA FACTORY

CSB BATTERY GUANGZHOU CO., LTD.  
No 97, Tianyuan Road, Yonghe Area,  
Guangzhou Economic Technology Development  
Zone, P.R.C.  
Postcode:511356  
Tel : +86-20-8297-9716  
Fax : +86-20-8297-9719

### AMERICA HQ

CSB BATTERY TECHNOLOGIES INC.  
2901, White Settlement Rd.  
Ft. Worth, TX 76107  
U.S.A  
Tel : +1-817-244-7777 /  
1-(800)3-CSB-USA(272872)  
Fax : +1-817-244-4445  
E-mail : [csb@csb-battery.com](mailto:csb@csb-battery.com)

### BENELUX OFFICE

CSB BATTERY BENELUX B.V  
Keurmeesterstraat 28-30  
2984 BA Ridderkerk  
The Netherlands  
Tel : +31 (0) 180413098  
Fax : +31 (0) 180418327  
E-mail : [eurosales@csb-battery.eu](mailto:eurosales@csb-battery.eu)

### GERMANY OFFICE

CSB BATTERY DEUTSCHLAND GMBH  
Südliche Auffahrtsallee 75  
80639 Munchen (Nymphenburg)  
Germany  
Tel : +49 (0) 800 1821 171  
E-mail : [eurosales@csb-battery.eu](mailto:eurosales@csb-battery.eu)

### SHANGHAI OFFICE (CHINA)

CSB BATTERY LOGISTICS (SHANGHAI) CO., LTD.  
Room2105, Qiang Sheng Tower, Pu Jian Rd.,  
Shanghai, China  
PC : 200127  
Tel : +86-21-50461622 / +86-21-50460833 /  
+86-21-50460094  
Fax : +86-21-50461046  
E-mail : [chinasls@csb-battery.com](mailto:chinasls@csb-battery.com)

### TAIWAN FACTORY

CSB BATTERY (GUAN TYAN) FACTORY.  
No.16, Gongye W. Rd., Ell Jenn Vil.,  
Guantian Dist., Tainan City 72048,  
Taiwan (R.O.C.)  
Tel : +886-6-698-7600  
Fax : +886-6-698-5734

### EUROPE HQ

CSB Battery Europe BV  
Keurmeesterstraat 28-30  
2984 BA  
Ridderkerk  
The Netherlands  
Tel : +31 (0) 180418140  
Fax : +31 (0) 180418327  
E-mail : [eurosales@csb-battery.eu](mailto:eurosales@csb-battery.eu)

### UK OFFICE

CSB BATTERY UK LTD  
Cobourg House, Mayflower Street,  
Plymouth PL1 1LG,  
United Kingdom  
Tel : +44 (0) 8082345420  
E-mail : [eurosales@csb-battery.eu](mailto:eurosales@csb-battery.eu)

### ITALY OFFICE

CSB BATTERY ITALIA S.R.L  
Corso Sempione 77  
20149 Milano  
Italy  
Tel : +39-800797614  
E-mail : [eurosales@csb-battery.eu](mailto:eurosales@csb-battery.eu)

### SHENZHEN OFFICE (CHINA)

CSB BATTERY LOGISTICS (SHANGHAI) CO., LTD.  
SHEN ZHEN BRANCH  
Room 2103-2105, Block East,  
City Professional Hub, Shennan Avenue, Futian,  
Shenzhen, China  
PC : 518040  
Tel : +86-755-88316488 / 6775 / 6075  
Fax : +86-755-88316548  
E-mail : [she@csb-battery.com.cn](mailto:she@csb-battery.com.cn)

### VIETNAM FACTORY

CSB Battery (VIETNAM) CO., LTD.  
Nhon Trach 3 IP, Second Phase,  
Nhon Trach District, Dong Nai Province  
Vietnam  
Tel : +84-61-3569120  
Fax : +84-61-3569165